



TABLE OF CONTENTS

| | |
|--|----|
| Tablet Capsule Counting Machine | 2 |
| Automatic 12-channel Tablet & Capsule Counting Machine | 2 |
| High Accuracy Tablet/Capsule Counting Machine | 8 |
| Fixture Rotary Counting Machine | 10 |
| Tabletop Capsule and Tablet Counting Machine | 12 |
| Tabletop Tablet Counting Machine (Capsule, Pill, Tablet Counter) | 14 |
| High Speed Automatic Capsule Counter | 19 |
| Automatic Capsule Tablet Counting Machine Line | 22 |
| Compact Tablet Counter mTC1000 | 24 |





TABLET CAPSULE COUNTING MACHINE



AUTOMATIC 12-CHANNEL TABLET & CAPSULE COUNTING MACHINE

SKU: TM4600

Automatic 12-channel Tablet & Capsule Counting Machine is an automatic counting packaging machine for dispensing capsules, tablets, pills, and sugar-coated tablets into bottles. TM4600 uses a KEYENCE high-accuracy optical sensor for product detection and provides high-speed counting via 12 feeding channels.

Compared with other counting machines with fewer channels, the Automatic 12-channel Tablet & Capsule Counting Machine has a higher production speed, as high as 2200- 6000 pieces/minute, which provides high-speed counting and filling production for the pharmaceutical industry and nutritional supplement industries.

In addition, the Automatic 12-channel Tablet & Capsule Counting Machine is easy to operate with a large touch screen. It can be applied to a variety of product counting without changing the parts of the feeding module to meet the needs of pharmaceutical and health food factories for automated pill counting and packaging.

How the multi-channel tablet and capsule counter achieves accurate counting.

The multi-channel tablet & capsule counting machine uses an optical sensor to detect the tablets/caplets passing through the gate for accurate counting.

First, set the required number of tablets, pills, or capsules to be counted and adjust the feeding speed according to your needs. Make sure the capsules and tablets to be counted are free of debris and remove any damaged, irregularly shaped products, then fill the product into the hopper.

Do not overload the hopper to prevent jamming, which may cause inaccurate counting.

After starting the machine, the products in the hopper will be dispersed and arranged on each channel through vibration. Then the optical sensor detects the product at the end of the channel.



Once the quantity reaches the set number, the gates will open and drop the product into the bottle through the filling nozzle.

Designed and manufactured in compliance with GMP, the perfect counting machine for the pharmaceutical industry.

The Automatic 12-channel Tablet & Capsule Counting Machine uses high-speed optical sensor systems and computer control systems to provide advanced technology for the pharmaceutical, biotech, food, and cosmetic industries to count and pack most types of tablets and capsules.

Automatic 12-channel Tablet & Capsule Counting Machine is especially ideal for the pharmaceutical and nutritional supplements industries. It does not have the problem of inconsistent product numbers from the weigh-filling system, and it is easier to maintain than a counting machine with a visual inspection system, meeting the accuracy and stability requirements of automated counting and filling production.

Our tablet and capsule counting machines are designed and manufactured according to GMP, whether you are a Chinese medicine factory, a Western medicine factory, a biotech pharmaceutical company, or a food factory, we can provide professional pre-sales consultation and perfect after-sales service to plan the most satisfactory counting and filling solution according to your needs.

Automatic 12-channel Tablet & Capsule Counting Machine combines high-speed counting, accuracy, versatility, and automation to help pharmaceutical and food packaging industries achieve better productivity.



Advantages:

- High-speed capsule and tablet counting: 12 channels for simultaneous counting of tablets or capsules for higher production.



- 100% Counting accuracy: Multiple channels for counting large numbers of tablets and capsules with high accuracy.
- Automatic dust detection: Maintain the stability of long-term production.
- Versatility: Able to count tablets and capsules of various sizes, shapes, and materials for a wide range of applications.
- Automation brings high efficiency
- Automatic counting reduces labor and increases overall efficiency.



Suitable Product Shape:

It can be applied to various sizes and shapes of tablets, lozenges, and capsules. It can be adapted to different products without complicated adjustment or parts replacement and is versatile enough to meet various production requirements, including tablets, capsules, pills, soft capsules, sugar-coated tablets, and other powder form tablets.



Suitable Industries:

Pharmaceutical industry, health food industry, biotechnology industry, food industry, and beauty industry, packaging OEM.

Suitable Container:

Various round bottles, polygonal bottles, square bottles, oval bottles, flat bottles, and packing bags (need to integrate with bag packing machine).



Suitable Bottle Material:

Glass bottles, plastic bottles, metal jars, ceramics.

Machine Layout:

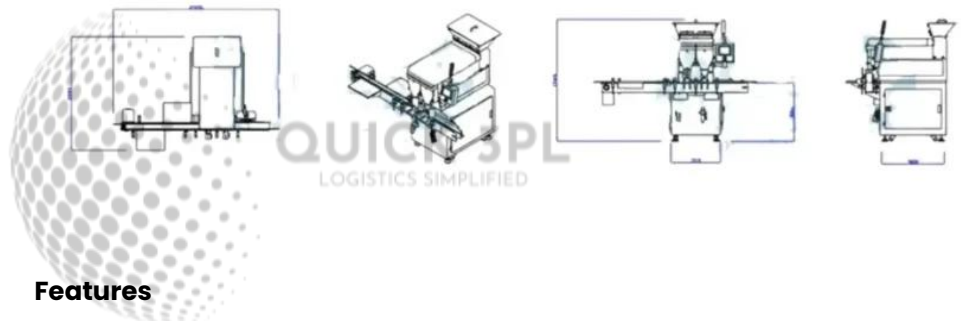

Features

1. Product feeding is performed by a 12-channel vibration feeding module, and the vibration frequency and speed can be adjusted by the operator.
2. Automatic 12-channel Tablet & Capsule Counting Machine has a counting module height that can be adjusted by the motor lifting device, so it is possible to fill bottles of different heights.
3. Automatic 12-channel Tablet & Capsule Counting Machine has a large-capacity hopper that can accommodate most tablets, lozenges, and capsules. Provides maximum versatility with no need to change components in the feeding module when changing counting products.
4. Automatic 12-channel Tablet & Capsule Counting Machine has a dust collection device that is used to prevent the powder of the tablet from affecting the counting accuracy.
5. HMI to monitor the process: Real-time display to ensure that the count is accurate and follows the set quantity, controlling the production progress.
6. HMI can memorize 100 sets of production recipes, including parameter settings and batch information, to improve the speed of line changeover
7. PLC controlled, and HMI touchscreen, adjustments and settings



- can be done through the touchscreen, convenient for different products to be produced alternately
8. The products are filled into the bottles or containers on the conveyor through the stainless-steel sanitary feeding system and bottle-feeding system while being accurately counted.
 9. Two-stage vibration feeding module is suitable for general capsules and round tablets and has excellent adaptability to irregular pellets.
 10. Automatic 12-channel Tablet & Capsule Counting Machine is suitable for capsules and tablets with a diameter of 4~40mm and a height of 4mm or more. (Other sizes can be customized)
 11. 12-channel vibration feeding module and 2 nozzles for high counting and filing speed
 12. The counting sensor is KEYENCE for accurate detection.
 13. Counting numbers can be set from 1-9999, meeting the needs of supplements and pharmaceutical packaging.
 14. The product contact material complies with the FDA to meet pharmaceutical, food, and cosmetic production.
 15. Plastic steel chain conveyor and guide rail, stable bottle conveying, and low noise.
 16. Automatic 12-channel Tablet & Capsule Counting Machine has a conveyor that can accommodate various sizes of bottles.
 17. Automatic 12-channel Tablet & Capsule Counting Machine's automatic bottle infeed and outfeed system, with accurate positioning of bottles.
 18. A counting machine can be customized with 8, 12, 16, or 24 channels. An automatic feeding machine can increase the production capacity.
 19. Quick detachable design, tool-free to disassemble and clean.
 20. Straight-line conveyor design, easy to integrate with other packaging machines.
 21. Food-grade plastic acrylic transparent cover.
 22. Set a target output, and the machine will stop automatically when the set output is reached.
 23. Automatic 12-channel Tablet & Capsule Counting Machine has an automatic alarm system, the machine can detect abnormalities to prevent defective products
 24. No need to reset the sensor for product change.

Specification

- **Automation Level:** Fully Automatic
- **Tablet/Capsule Size :** (Dia.)4~40mm; (H)>4mm: NO.000~NO.5
- **Counting Speed:** 2200~6000 pcs/min (depending on product size and shape)
- **Accuracy:** 100% (with proper speed)
- **Bottle Size :** (Dia.)38~100mm; (H)60~220mm
- **Power Supply :** 110 or 220VAC, 50/60Hz, single phase
- **(Electrical system per overseas regulations is available)**
- **Air Supply:** 40~60 PSI
- **Machine Size :** (L)2100mm (W)1504mm (H)1754mm
- ❖ **Actual product specifications may vary**



QUICK 3PL
LOGISTICS SIMPLIFIED

Option Accessories

- Weight checking system.
- Customized conveyor.
- Advanced HMI: Permission management, production history, batch data.
- Counting and bottling line solution (bottle scrambler, air rising machine, cotton inserter, desiccant inserter, capper, induction sealer, and labeler)
- Pouch packaging machine.

Category: [Tablet Capsule Counting Machine](#)



QUICK 3PL
LOGISTICS SIMPLIFIED



HIGH ACCURACY TABLET/CAPSULE COUNTING MACHINE

SKU: TM4200

High accuracy tablet/capsule counting machine TM4200 is suitable for irregular shape and regular shape of tablet and capsule counting requirements in bottles and bags. With a PLC user-friendly control system and touchscreen, it is easy to operate without training and adjustments to save downtime and boost productivity.

Features

1. Automatic tablet/capsule counting machine with conveyor system, can be connected with other automatic machines easily.
2. Anti-dust mode to ensure counting accuracy in an environment full of dust.
3. The dual-counting machine can run individually.
4. An accurate bottle index system and bottle stopper.
5. High Accuracy Tablet/Capsule Counting Machine is equipped with a dust accumulation tray for cleaning dust.
6. High Accuracy Tablet/Capsule Counting Machine has a PLC user-friendly control system and touchscreen for easy operation.
7. Memory parameter for fast changeover without reset.
8. High Accuracy Tablet/Capsule Counting Machine has an advanced sensor detection system for precise counting.
9. Any errors will show on the touchscreen to avoid mistakes.
10. High Accuracy Tablet/Capsule Counting Machine is made of stainless steel and complies with the CGMP standard.
11. Stainless steel foot type with casters for ease of movement.

Specification

- **Counting speed:** 1200~2000 pcs/min
- **Tablet size:** height > 2mm, diameter 2~40mm
- **Accuracy:** 100%
- **Power supply:** 220VAC, 50/60Hz
- **Air pressure requirement:** 2CFM at 90 PSI
- **Dimension:** (L) 2000mm (W)1000mm (H)1500mm

Option Accessories

- Protect casing

Category: [Tablet Capsule Counting Machine](#)



QUICK 3PL

LOGISTICS SIMPLIFIED



QUICK 3PL

LOGISTICS SIMPLIFIED



FIXTURE ROTARY COUNTING MACHINE

SKU: NTC-120



Fixture rotary counting machines are suitable for multiple products to count, fill, and pack. Customized fixture rotary counting machines not only fit in pharmaceutical or food products, but also in the electronic and metal manufacturing industries.

Screws, components, metal components, electronic components, buttons, capsules pills and tablets will be precisely counted and filled in to bags or bottles after setting the number of the product. The packaging methods are not restricted by the way of filling bottles, aluminum foil bags, ziplock bags, etc.

High Efficiency Counting Machine

Double-feeding fixture rotary counting machine quickly fills alternately by two infeeds, and the CCD can detect with high precision, actively detecting abnormal situations. Insufficiency or jams will lead the machine to automatically halt.

Special material fixture rotary counting machines are appropriate for diverse products, connecting filling machines to become automatic counting and filling machines to save manpower costs.

Features

1. Fixture Rotary Counting Machine has an automatic dust collection device to prevent errors in counting.
2. Fixture Rotary Counting Machine is designed to run stably and count fast.
3. The time interval is fixed to feed with 100% accuracy.
4. Fixture Rotary Counting Machine has a Japanese high-precision CCD to perfectly locate products and count.
5. Fixture Rotary Counting Machine's counting speed can be adjusted on demand with a range of 600~900 ppm.
6. Coordinate with vibrating feeding machines to substitute manpower, saving labor.
7. Customized production according to specialized products with a wide range of usage.
8. Fixture Rotary Counting Machine's CCDs monitor all the lines, automatically halting instantly if any insufficiency or jams
9. Rotary feeding tank can feed the tablets on demand with a continuously variable.
10. Sophisticated high-speed rotary table allows for feeding 30,000 tablets or capsules at a time, saving time by decreasing resupply times.
11. Fast changeover per the different sizes and shapes of granules



- easily and swiftly.
12. Human-machine interface with a PLC control program can adjust the speed of counting easily.
 13. A two-sided counting system mounted to feed alternately, increasing productivity without halting the operation due to the changeover.
 14. Fixture Rotary Counting Machine is made of SUS#304 stainless steel and aluminum alloy. It is durable and anti-rust, and conforms to the cGMP standard.

Specification

- **Counting speed:** 600-900 pieces/min (varied by types and sizes)
- **Accuracy:** 100%
- **Applicable Size:** diameter > 3mm, height > 3mm
- **Power required:** Single-phase 110 or 220 VAC, 50/60 Hz
- **Weight:** 50 Kg
- **Size:** (L) 1325mm (W) 930mm, and (H) 1150mm

Option Accessories

- Feeding Machine
- Filling Machine
- Date coding Machine

Category: [Tablet Capsule Counting Machine](#)





TABLETOP CAPSULE AND TABLET COUNTING MACHINE

SKU: TM1100

Tabletop Capsule and Tablet Counting Machine precisely counts and fills bottles by electronic automatic vibration. Tabletop double-rail counting machines are easily operated to work with simple parameter settings.

Module-designed Tabletop Capsule and Tablet Counting Machines are suitable for precisely counting many kinds of types and sizes of tablets, capsules, tablets, flakes, troches, dragées, and chocolate balls. The counting range can be set up from 1 to 9,999 pieces.

High Quality Tabletop Capsule And Tablet Counting Machine

The tabletop capsule and tablet counting machines fit into a small environment and can be applied to many kinds of products without switching components. The counting and filling modes are diverse and can be used in filling different types of bottles, cans, and bags etc. The machine body is small and light to move around.

The tabletop double-rail counters can be used in hospitals, pharmaceutical factories, food factories, cosmetic factories, and clinics, and they all conform to the cGMP regulations. With the fast counting feature of the tabletop double-rail capsule and tablet counting machines, and cooperating with filling machines, the packaging productivity and efficiency can be accelerated.

Features

1. Tabletop capsule and tablet counting machine feeds smoothly with no jams
2. Tabletop Capsule and Tablet Counting Machine's counting settings range is from 1-9999 pieces with high precision
3. Concise design and easy to operate, and clean
4. Unique dust collecting devices to prevent dirt, keeping a high precision of counting
5. Tabletop Capsule and Tablet Counting Machine fits into any capsules and tablets of 2-40 mm in diameter, above 2 mm in height
6. Tabletop Capsule and Tablet Counting Machine's Microcomputers that offer precision and reliability.
7. Multiple parameter settings available, different products count anytime to increase efficiency
8. Alterability to vibrating control; double rails allow fast counting
9. Tabletop Capsule and Tablet Counting Machine adopts the



- Japanese Keyence High Accuracy CCD to ensure high precision.
10. Coordinating the counting speed with the product conveying needs
 11. Great mobility to change other product counting without switching machinery components
 12. Many products are suitable: capsules, tablets, dragées, flakes, etc.
 13. PLC-controlled program and human-machine interface to quickly and easily operate
 14. Tabletop Capsule and Tablet Counting Machine has a transparent sealed anti-dust shell for sanitation and safety
 15. Tabletop Capsule and Tablet Counting Machine is constituted by stainless steel and hardened aluminum alloy, conforming to cGMP regulations
 16. Tabletop Capsule and Tablet Counting Machine has a 5-liter tank to resupply less frequently.

Specification

- **Accuracy:** 100%
- **Counting Speed:** 600-1000 pieces/min (varied by types and sizes)
- **Power Needs:** Single phase 110 or 220 VAC, 50/60 Hz
- **Air Pressure Requirement:** 2 CFM at 90 PSI
- **Bottle Diameter:** 48mm ~ 100mm
- **Bottle Height:** Maximum of 116 mm

Option Accessories

- 5L hopper
- Conveyor belt
- Drugs pre-fill machine
- In line capping, labeling system

Category: [Tablet Capsule Counting Machine](#)



TABLETOP TABLET COUNTING MACHINE (CAPSULE, PILL, TABLET COUNTER)

SKU: TC1000

Tabletop Tablet Counting Machine TC1000 is designed for high-speed and precision quantitative counting for tablets, soft/hard capsules, and so on. The maximum output is 1000 pieces per minute. TC1000 can set figures to fill your product into containers such as bags and bottles.

When operating Tabletop Tablet Counting Machine, put your products in the hopper, the vibration unit will send them into the tempered glass turntable to line up, the photoelectric sensor unit will then fill the products into the container precisely according to the figures set on the control panel.

Tabletop Tablet Counting Machine is suitable for any regular pattern products, it has a diameter of 6mm or above and a height of 3mm or above. The known product that is suitable for this counter is soft/hard capsules, tablets, chewing gums, star-shaped products, pills, dragees, lozenges, troches, etc...

Dual nozzles have high-speed quantitative counting and can count a variety of products.

Tabletop Tablet Counting Machine has single/dual channel filling modes, which can be set according to production requirements. The fast blanking unit does not jam when the product is counted. The photoelectric sensor can meet high precision quantitative counting, while the glass turntable conveys product through high-speed turning.

The double nozzles can fill two containers at once to meet the high efficiency production. The production speed can be adjusted according to the actual product and production capacity to make the production more flexible.

The TC1000 Tabletop Tablet Counting Machine is suitable for various sizes of products. The vibration frequency and the glass turntable turning speed can be adjusted depending on the products to meet the best production capacity. The control panel of the machine can easily set the counting figures and output.

The Tabletop Tablet Counting Machine is easily operated, no special training required, one man can complete all operations, and no tools are needed when changing products.

Tabletop Tablet Counting Machine can be supplied to a hospital pharmacy, small mid-scale biotech company, dietary supplement manufacturer, cosmetic manufacturer, grocery manufacturer, or tablet/capsule manufacturer for counting needed.



A single machine can achieve various types of product counting and filling. TC1000 can also be customized with different labeling machines, capping machines, date coders, and other packaging machines into production lines for tablets, capsules, and any products that are suitable for this machine.

Advantages

1. Obtained CE certification
2. High speed counting and filling, 600-1000 pieces per minute (according to product size)
3. Dual nozzles are filled in turn, alternating operation, time-saving, and high-efficiency
4. Can count product such as tablets, capsules, pills and screws
5. Meet the specifications of current good manufacturing practices (cGMP)
6. Can also count products such as candies and chocolates

Application & Advantage

Tabletop Tablet/Capsule Counting Machine applicable product

All kinds of granular/particle products that require counting, such as tablets, capsules, lozenges, film-coated tablets, dragees, soft/hard capsules, pills, peppermint tablets, chewing gum, cod liver oil, candy, chocolate balls, beads, beans, buttons, laundry detergent capsules.

Applicable industry

Pharmaceutical manufacturer, Chinese Pharmaceutical manufacturer, biotechnology companies, dietary supplement manufacturer, cosmetics manufacturer, grocery manufacturer, laboratories, large hospitals, and large pharmacies.

Packing method

Any bottle containers and bag containers.



Q & A

Q1: Can the TC models' counting machine count soft candy?

A: It depends on the product's characteristics. The TC models counting machine is suitable for non-sticky products with a regular shape. If the surface of the product is irregular in shape, sticky, or has sugars that are easy to deliquesce, these products will not be able to roll on the turntable for counting and filling. If your soft candies are similar to capsules, tablets, flakes, and balls, with no stickiness between them, you can use this type of counting machine to fill your product.

Q2: Our counting machine has two kinds of model, s TC and TM. What is the difference, and how to choose between them?

A: Both types of counters are suitable for counting capsules, tablets, pills, and other products. The counting speed of the TC models' counting machines is faster, and the accuracy and speed performance are optimized when counting products with regular shapes. The TM models of tablet counting machines are slower than the TC models, which are more suitable for products that are fragile and high-priced.

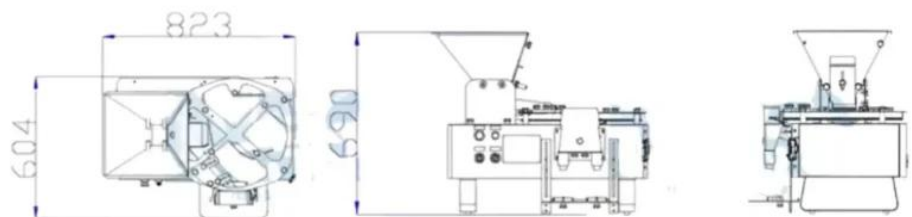

Features

1. The Tabletop Tablet Counting Machine is suitable for the pharmaceutical, hospital, and food industries to count and fill product such as capsules, tablets, grain beans, etc.



2. Tabletop Tablet Counting Machine is applicable to all kinds of capsules, pills, and tablets with a diameter of 6mm or above and high 3mm or above.
3. The counting number can be set to count from 1 to 9999, and the setting is simple
4. Dual nozzles are filled in turn, alternating operation, which is in line with the humanized two-handed operation habits
5. Counting of different types of products without further adjustment
6. Blanking vibration prevents product jams, and the blanking speed can be adjusted
7. Tabletop Tablet Counting Machine has a high-standard food-grade hopper to avoid pollution and residues
8. The feeding speed of the turntable can be adjusted according to the diameter of the product to reach the best production capacity
9. The output of the container and the counting of pieces can be set
10. Tabletop Tablet Counting Machine has a PLC control program and LCD human-machine interface, easy to set and operate
11. Counting different products without changing models and components
12. Rotary counting, precise computer detection, high-speed precision counting, and stable operation
13. Tabletop Tablet Counting Machine is equipped with a dust collection device to protect the sensor and ensure the accuracy of counting
14. Japan's high-precision photoelectric sensor, precision counting.
15. Electromagnetic vibration blanking, when the bottle is placed at the outlet, the tablets or capsules pass automatically
16. Set the counting speed, and freely set the production speed according to the capacity
17. Tabletop Tablet Counting Machine is customized large hopper, reducing the number of refills during production
18. Touch screen monitor for real-time monitoring of outputs with a parameter memory function that can memorize multiple production formulas
19. Tabletop Tablet Counting Machine has a safety protection device with emergency stop button to ensure the safety of operators
20. The components in contact between the machine and the product are made of 316 stainless steel, which meets the current cGMP good manufacturing conditions for pharmaceuticals
21. The component that contacts the product can be removed without tools, for easy cleaning and maintenance

Specification

- **Capsule size:** Diameter > 6mm, Height > 3mm
- **Tablet size:** 2mm ~ 30mm
- **Counting speed:** 600 ~ 1,000 pcs/min (varied by types and sizes)
- **Accuracy:** ± 1 tablet
- **Bottle size:** diameter: 48mm ~ 100 mm/height: 116mm
- **Power supply:** 110/220VAC, 50/60Hz
- **Machine dimension:** (L) 822mm (W) 588mm (H) 739mm
- * Machine dimensions may vary due to adjustments in their



design.

Option Accessories

- Automatic bottle infeed system
- Bottle arranging system
- Bottle locating system
- Dust guard

Category: [Tablet Capsule Counting Machine](#)





HIGH SPEED AUTOMATIC CAPSULE COUNTER

SKU: TC4200

High Speed Automatic Capsule Counter can calculate precisely tablets, capsules, pills, troches, dragées, and chocolate, etc., of any type and size to fill them into many products. Automatic PLC-controlled comprehensive location, bottle infeed, bottle splitting, counting, and filling lead to efficient manpower.

High Speed Automatic Capsule Counter allows to have 20 sets of parameters for multiple counting productions at the same time.

High Efficiency High Speed Automatic Capsule Counter

We adopt double-rail high-speed automatic counting and double feeding counting machines, and the filling process works constantly and efficiently. The highly sophisticated electrical High Speed Automatic Capsule Counter adjusts and detects via computers, and the change-overs do not need to switch any components to save more time and enhance productivity easily.

For those products with a large amount of dust, we provide dust-collecting devices to solve the problem. The independent CCD systems do not affect the accuracy of counting. The productivity of counting is up to 1600 to 2400 per minute, per the size of the products.

The High Speed Automatic Capsule Counter has photoelectrical sensors that can detect counting errors and remove them. It is the primary choice of counting and packaging facility for many Chinese & Western pharmaceutical, biotech, healthy food, and OEM factories to manufacture efficiently.

Features

1. Automatically splitting, precisely locating, and filling bottles
2. Automatically rotary and double feeding are connected with the production line to enhance the productivity
3. Fast access to 20 sets of parameters to quickly start working and change over
4. High Speed Automatic Capsule Counter fits into different sizes and shapes of hard or soft capsules and tablets, with no need to change modules for change-overs
5. Counting accuracy during production in a highly abundant dust environment will not be affected.
6. High Speed Automatic Capsule Counter has an automatic PLC control, and a human-machine operational interface allows convenient operation.



7. Special anti-dust CCD can be adjusted without affecting accuracy according to the dust for products that easily cause highly abundant dust.
8. High Speed Automatic Capsule Counter has an automatic error detection systems that remove the counting error and save time on checking.
9. High Speed Automatic Capsule Counter has high-standard and sophisticated Japanese photoelectrical sensors that allow zero counting error.
10. High Speed Automatic Capsule Counter has an alarming system that notifies operators after finishing counting.
11. High Speed Automatic Capsule Counter fits into filling, counting, and packaging in different sizes of bottles, and is easy to adjust.
12. Automatically locate, infeed, split up, feed, count, and fill in the same production line
13. Flexibly choose to work with one or two machines according to the production needs
14. Mounted with an automatic bottle splitting system to precisely locate bottles
15. Automatic infeed by conveyors to save time on conveying and manpower
16. High Speed Automatic Capsule Counter has an exclusive dust-collecting device cthat an easily remove dust and powder
17. Micro-computer detection adjusts machines automatically, is easy to maintain, and is user-friendly.
18. Mounted with an excellent PLC program and human-machine interfaces to count quickly and fill stably.
19. The rotary table and the speed can be adjusted in accordance with productivity, and sizes in special diameters can be customized.
20. High Speed Automatic Capsule Counter conforms to cGMP regulations, being solid, durable, and lasting with a long life.

Specification

- **Counting speed:** 1600-2400 pieces/minute (varied by product kinds and types)
- **Sizes of products:** 6mm in diameter; more than 3 mm in height
- **Accuracy:** 100% in a proper speed, ± 1 piece for over-speed
- **Power:** 220VAC, 50/60Hz
- **Size of Machine:** (L) 2400mm (W) 1000mm (H) 1500mm

Option Accessories

- Transparent anti-dust shell
- Automatic capping machinery production line facility

Category: [Tablet Capsule Counting Machine](#)



QUICK 3PL

LOGISTICS SIMPLIFIED



QUICK 3PL

LOGISTICS SIMPLIFIED



AUTOMATIC CAPSULE TABLET COUNTING MACHINE LINE

SKU: TC4100 / RT1060 / RT2060

Automatic Capsule Tablet Counting Machine Line equipped with an automatic bottle-feeding turntable that transports the bottles to the counting machine and outfeed turntable through a conveyor, reducing the repetitive workforce on placing and picking the bottles manually.

Different from its tabletop, single machine version, the turntable made this production line more efficient. Compact design makes it suitable for limited space and easy to change over for different products.

Automatic Capsule Tablet Counting Machine Line is suitable for extensive fields of industry, including pharmaceutical, food, chemistry, and cosmetics. Applications include bottled gums, vitamins, pills, capsules, tablets, fish oil, candy, etc.

Space / Manpower-Saving Compact Design Automatic Counting Machine Line

Automatic Capsule Tablet Counting Machine Line has high accuracy, and either vibration speed or counting quantity is adjustable depending on your needs. Furthermore, to meet your requirement, the bottle infeed / outfeed speed of the turntables is adjustable. The size of the star wheel is also customizable.

All parts that contact your product are made of stainless #316, which meets the high standards of the pharmaceutical industry. Capping machine, sealing machine, and round bottle labeler are also available to upgrade your fully automatic production line.

Features

1. Automatic Capsule Tablet Counting Machine Line equipped with infeed / outfeed turntable. Saving your time and manpower.
2. Automatic Capsule Tablet Counting Machine Line is easy to maintain; simple to clean.
3. Multiple parameter settings are adjustable: Quantity of bottle/ capsule, Goal amount of bottle/ capsule.
4. Automatic Capsule Tablet Counting Machine Line has an automatic counting recorder lets you see the exact bottle/ capsule counting number.
5. Moveable design for equipment rearrangement/ expansion to a fully automatic counting, filling production line.
6. Adjustable conveyor speed, product infeed/outfeed speed, and counting speed.
7. Automatic Capsule Tablet Counting Machine Line has a PLC



- programmed HMI system with a colored touch screen and a clear display, allowing convenient operation.
8. Automatic Capsule Tablet Counting Machine Line fits for counting coated capsules, pills, tablets, and particles.
 9. Automatic Capsule Tablet Counting Machine Line has a dust accumulating device for smooth, efficient, and accurate counting
 10. Automatic Capsule Tablet Counting Machine Line meets cGMP requirements. Product contacting parts are made of materials meeting pharmaceutical standards.
 11. With humanized mechanical design, there are no tools needed for product changeover.
 12. Automatic Capsule Tablet Counting Machine Line is environmentally friendly, and no production consumables are needed.

Specification

- **Counting speed:** 500-1000 pieces/minute (varied by types and sizes)
- **Voltage:** 110/220 VAC, 50/60 Hz
- **Bottle size:** diameter: 48 mm ~ 100 mm/height: 116 mm
- **Capsule size:** diameter > 6 mm, height > 3 mm
- **Tablet size:** 2 mm ~ 30 mm
- **Accuracy:** ± 1 tablet
- **Dimension:** (L) 2500 mm (W) 1800 mm (H) 1300 mm
- **Net weight:** 450 kg
- **Spare parts:** handwheel, screw, power cable, dust accumulating box, vibration plate, nozzle

Option Accessories

- Capping machine
- Sealing machine
- Round bottle labeling machine
- Coding machine

Category: [Tablet Capsule Counting Machine](#)



COMPACT TABLET COUNTER MTC1000

SKU: mTC1000

The compact tablet counter is dedicatedly designed to count and subpackage tablets, capsules, and other solid medicines. mTC1000 is a small tablet counting equipment designed for pharmacies, hospitals, laboratories, and other small-scale manufacturers.

Compact Tablet Counter mTC1000 is compact and easy to operate, capable of counting and subpackaging medicines such as tablets, hard capsules, pills, and lozenges, or health supplements and food into bottles or bags.

Compact Tablet Counter mTC1000 is known for its high efficiency, easy-to-operate design, high accuracy counting, and it is capable of counting around 600 tablets per minute. This makes it best suited for small- to medium-scale manufacturing, providing an efficient and stable production method.

No need to adjust for different products, count various tablets and capsules with ease.

Compact Tablet Counter mTC1000 is capable of handling tablets, capsules, and pills of various sizes and shapes. It is suitable for products with a diameter of 6 mm, a thickness of 3 mm, and the above.

Not only those, it is also not a stranger to soft and hard capsules, tablets, pills, pellets, sugar-coated pills, buccal tablets, mint tablets, and chewing gums that are consistent in shape and are not sticky. The mTC1000 does not need a complicated adjustment to be able to count the products; it is flexible and convenient.

High-Efficient Dual-Track System to Increase Production Capacity and Accuracy.

Compact Tablet Counter mTC1000 equipped with dual tracks that can discharge tablets continuously and dual filling nozzles to subpackage two bottles at the same time, the mTC1000 is user-friendly, highly efficient for its two-handed operation design.

Compact Tablet Counter mTC1000's counting speed can be adjusted based on product and production requirements. Paired with the rapid discharge device, it will not slow down or have tablets stuck inside when counting.

The product feeding speed can be adjusted directly by the knob based on the product type to reach a stable production capacity. It is an easy-to-operate small counter that requires no tools when changing the containers, and it also requires no special training to use; one person is all you need to complete all of the operations.



This highly cost-worthy tablet counter not only can raise production efficiency, require no air compressor, but can also utilize the space effectively, making it the top choice for small and medium pharmacies and health supplement manufacturers.

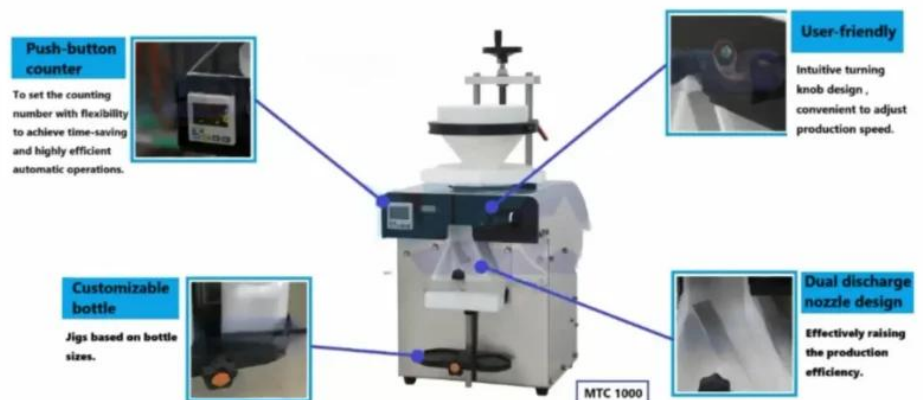

Our Advantages:

1. Small and compact design: Phenomenal space efficiency, all you need is a small, flat surface to set up a production line, making it easier to plan circulation within limited space.
2. Multifunctionality: Compact Tablet Counter mTC1000 is applicable to tablets and pills with diverse sizes and shapes.
3. High Precision Counting: Sophisticated detection counting, same amount of tablets per bottle, ensuring production consistency.
4. High-Efficiency Production: Dual discharge design to cross-fill continuously, greatly increasing subpackaging efficiency.
5. Stable Performance: Counts 150 to 200 tablets per minute (Based on tablet size) and automatically sub packages them.

Applicable Products:

1. **Pharmaceutical: Compact Tablet Counter mTC1000** can count medicines such as tablets, pills, soft capsules, etc. Ensuring the dosages are correct across the bottles or packages so that the patient can take with medication safely and follow the drug regulations.
2. **Biotechnology:** Health supplement companies often utilize tablet counters to count health supplements or vitamins in the form of capsules or pills, such as herbal supplements, various vitamins, minerals, fish oil, amino acids, and protein supplements.



3. **Food & Beverage:** Can be applied to count small pieces of food such as Candy, sugar-coated pills, chocolate balls, chewable supplements, mints, lozenges, or functional food in the form of tablets and capsules, or any other edible products that need precise packaging.
4. **Cosmetics:** Compact Tablet Counter mTC1000 is suitable for beauty and cosmetics industries with products such as beauty care products, essence, capsules, skin-care capsules, beauty-assist vitamins, hair-care capsules, and beauty essence capsules, etc.
5. **Chemicals:** Main Application: Some chemicals in the form of tablets or pellets that require precise counting and subpackaging, such as chemical cleaning tablets, clothes washer capsules, laboratory reagents, etc.
6. **Veterinarian:** Main Purpose: To dispense medicines precisely for animals of various types in the field of veterinary. Countable products: animal medicines, vitamins, and pet health supplements.



Applicable Industries:

Pharmaceutical factories, biotechnology companies, health supplement manufacturers, cosmetics, food factories, laboratories, hospitals, pharmacies, and clinics.

Packaging Method:

Plastic bottles, glass containers, and package bags.





Applicable Product Types:

Hard capsules, soft capsules, pills, circular tablets, oval tablets, tablets, pellets, heart-shaped tablets, diamond-shaped tablets, triangle tablets, polygon tablets, and irregular-shaped tablets.

Layout:

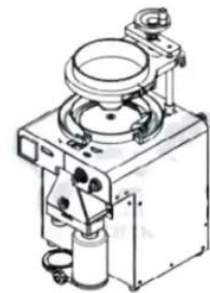
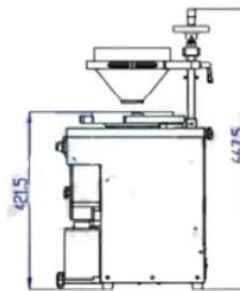
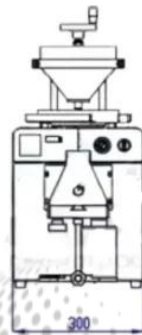

QUICK 3PL
LOGISTICS SIMPLIFIED

Features

1. No air compressor is needed, nor the loud noise from it when running. Improving the comfort in the working environment, best suited for hospitals and clinics.
2. The counting number can be freely set from 5 to 2500, using a button to set it, easily and conveniently.
3. Equipped with a refined photoelectric sensor counting system, the high precision counting ensures each subpackaging number is correct.
4. Vibrating discharge control can prevent the tablets from being stuck, and you may adjust the discharge speed based on products or your needs.
5. Dual filling nozzles rotate the discharge and produce without stopping. More user-friendly for the two-hand operation design, raising production efficiency.
6. Compact Tablet Counter mTC1000 is commonly applied to pharmacies, hospitals, food industries, pharmaceutical manufacturers, and laboratories, etc., for capsules, tablets, pills, and pellets, etc., to count, bottle, or package.
7. Smart control features with a user-friendly interface. The vibration frequency can be adjusted based on different product types to accommodate different product requirements with flexibility and greatly increase production efficiency.
8. Set the counting number with only one click; no tools are needed



- to change the bottles. The quick-release structure makes changing products easy. You do not need any professional training to be able to pick up the machine with ease.
9. Requires only electricity to use, no air required, and no more noise from air compressors.
 10. Compact Tablet Counter mTC1000's compact size is to utilize the limited production space to its fullest potential.
 11. Turning knob control vibration system that can be adjusted with flexibility based on the target product's diameter to ensure the maximum production capacity is reached.
 12. Strict quality control and test processes to ensure each machine can run stably for the long term.
 13. An automatic subpackaging system to reduce the workforce needed to operate the machine and raise the production efficiency.
 14. Strictly follow health standards to ensure the production process meets the industry regulations so that the products are safe and hygienic.
 15. Compact Tablet Counter mTC1000's advanced technology and stable performance make it vital equipment for various industries to raise production efficiency and improve competitiveness.

Specification

- **Degree of Automation:** Semi-automatic
- **Tablet Size:** (Length) 10 mm~25 mm; (Height)>2mm NO.000~NO.5
- **Counting Speed:** 400~600 pcs/min (Varies based on tablet size and shape)
- **Counting Precision:** 100%
- **Applicable Bottles:** (Diameter) 25mm~60mm; (Height) 40~140mm
- **Power Supply:** 110 or 220 VAC, 50/60Hz, single phase
- **Machine Size:** (L)360mm (W)300mm (H)670mm
- ***Actual machine size may vary; the machine size to subject to the actual machine.***

Option Accessories

- Bottle Jig
- Dust Cover
- Trolley

Category: [Tablet Capsule Counting Machine](#)



QUICK 3PL

LOGISTICS SIMPLIFIED



QUICK 3PL

LOGISTICS SIMPLIFIED



INDEX

A

- Automatic 12-channel Tablet & Capsule Counting Machine 1
- Automatic Capsule Tablet Counting Machine Line 21

C

- Compact Tablet Counter mTC1000 23

F

- Fixture Rotary Counting Machine 9

H

- High Accuracy Tablet/Capsule Counting Machine 7
- High Speed Automatic Capsule Counter 18

T

- Tabletop Capsule and Tablet Counting Machine 11
- Tabletop Tablet Counting Machine (Capsule, Pill, Tablet Counter) 13

